

## Plantronics CS70 with GN Netcom SeleCT Switch

### Set-Up and Instructions for Use

Although intended for use with a telephone, the Plantronics CS70N provides excellent accuracy when used in conjunction with the SeleCT Switch and a personal computer (PC). When used with this switch, the microphone can be toggled back and forth between telephone and PC, depending upon your needs.

**Preliminary Set Up:** First you must make the basic connections of the CS70N, SeleCT switch to your PC and telephone. Although there are alternative methods of making the connections, and these are described in the literature contained in the CS70N and SeleCT switch, the following figures show typical arrangements:

Figure 1: Standard Set-Up

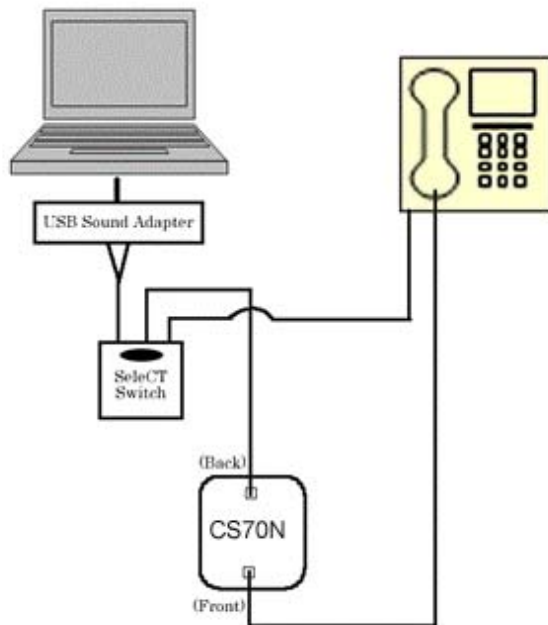

Typical Setup in which CS70N is used for both personal computer and PC. SeleCT switch is used to toggle between CS70N output to either telephone or PC.

Figure 2: Computer Only Set-Up

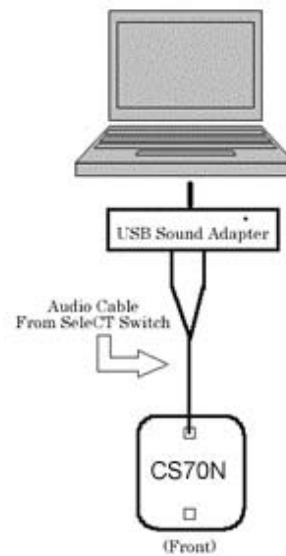

Simple setup in which CS70N is used only for PC. SeleCT switch is omitted but audio cable from SeleCT switch is used to the to make connection from CS70N to PC (or sound adapter)

#### Details:

1. A connection must be made from the receiver on the telephone to the modular "handset" jack towards the front of the CS70N bottom.

2. A connection must be made from the modular jack toward the back of the CS70N bottom to the middle jack on the GN Netcom SeleCT switch.
3. A connection must be made from the right jack of the SeleCT switch into the modular jack on the phone base into which the receiver cord would normally attach.
4. The cord which splits into two 3.5 mm audio plugs is attached to the leftward modular jack on the SeleCT switch and connects to the personal computer, either directly into the audio and mic input jacks or (preferably) via an external USB sound adapter.

Note: If you do not intend to use the CS70N with your telephone (and only with your PC) you can simplify the set-up by simply attaching the bifurcating audio cable that comes with the SeleCT switch directly from the modular jack on the back of the CS70N base directly to your PC or sound adapter. In this situation the switch isn't needed and nothing will be plugged into the front modular plug on the base of the CS70N (see Figure 2 above)

Note 2: If your telephone has a modular "headset" jack, the connections can be simplified. In this situation it is not necessary to attach anything to the plug toward the front of the CS70N bottom (see figure 3 below) and the telephone headset cord is undisturbed.

Figure 3: Set-Up with Telephone Having Modular "Headset Jack"

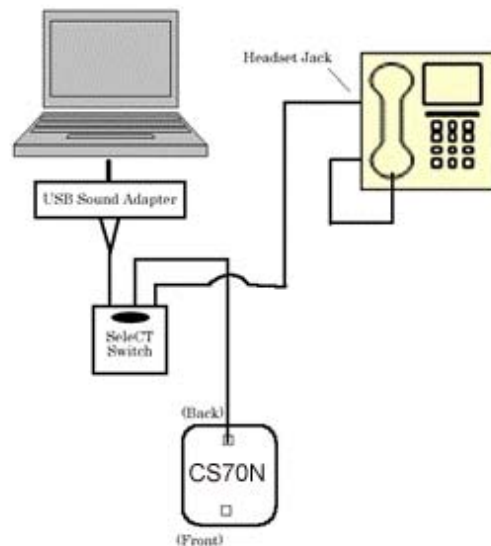

Optional set-up for use with telephone having dedicated modular "headset" jack. In this situation answering and placing calls involves activating the "headset" button on the phone.

### Preparing the CS70N for use with your Telephone and Personal Computer:

1. First you should plug in and charge the CS70N per the Plantronics instructions (it takes 3 hours for a full charge and 20 minutes is the minimum to allow further setup).

2. The "Compatibility" setting of the CS70N may need to be adjusted via the small rotary dial on the left of the unit. It is preset to position "1" and this tends to work best with most telephones and PCs. If necessary, you may need to try this in other positions.
3. Connect the CS70N (via the SeleCT switch) to your PC, preferably with the use of a USB sound adapter
4. Set the sound output volume of the CS70N. This is done with a "crude" and then a fine method. The crude output is set with the sliding switch on the bottom of the unit with A being the least output and D the greatest. Selecting "B" is recommended to start. Fine-tuning the CS70N output is accomplished using the small "+" and "-" buttons on the back of the CS70N and should be done while running the audio set-up wizard as described in the next step.
5. Make a preliminary test of the set up with NaturallySpeaking, by opening NaturallySpeaking and running the Audio Set-up Wizard. (Remember that you need to "activate" the microphone by pressing the large button on the outside of the ear-worn unit – this will cause the green light on the base unit to turn on)
6. When using the audio set-up wizard, note the level of the audio adjustment shown in the graphical display as shown below. The higher the blue bar, the higher the gain dragon is initiating and the lower the blue bar the less gain or amplification Dragon is applying. Ideally this bar should come up about ¼ to 1/3 of the way from the bottom.



If the blue bar is extending much higher than this, then you should use the adjusting buttons on the CS70N to increase the sound output a bit (pressing the "+" button a time or two). If the blue bar is all the way down at the bottom or not visible, you should adjust the CS70N output volume down by pressing the "-" key a few times. Experiment with this until the blue bar extends up ¼ to 1/3 after doing your sound test.

### Using the CS70N:

1. With your PC:
  - After dealing with the logistics of physical set-up and adjusting the output volume of the CS70N as described above, simply move the rocker switch on the SeleCT switch to the left in order to output the sound to your PC

- Be sure you turn on the microphone by pressing the long button on the outside of the head-worn unit – this will result in the green light on top of the CS70N base unit illuminating
  - Because the sound coming from the CS70N may be a bit different from sound originating from standard microphones, we have found that it is best to create a new user profile on Dragon. After doing so, you will observe outstanding accuracy when using the CS70N
2. With your telephone:
- In order to answer a call be sure the rocker switch is pushed toward the right (telephone position), be sure you have turned on the wireless microphone by pressing the long button on the outside of the wireless unit, and then simply lift your receiver from the cradle.
  - If you have connected by means of a modular “headset” jack on your telephone (described above), simply activate the “headset” button on your telephone to answer or place a call.

Good luck. Please call Speech Recognition Solutions with any questions pertaining to the set-up and use of this system.